

A099 Combination Lock

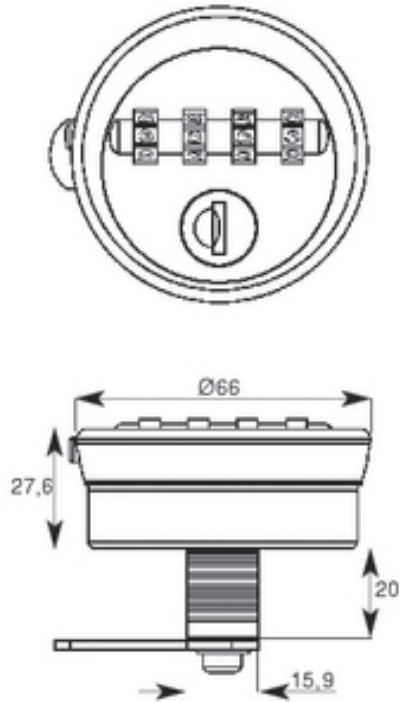

PRODUCT REFERENCE NUMBERS		
PRODUCT REF	NUMBER OF CODES	LOCK FIXING
A099	10000	NUT
<p>MAXIMUM PANEL THICKNESS : 12mm</p> <p>STANDARD MOVEMENT: 01, 02 (SETTING FOR LEFT OR RIGHT HINGED DOORS VIA SWITCH ON THE BACK OF THE LOCK)</p> <p>STANDARD FINISH: NICKEL PLATED HOUSING, SOFT TOUCH COLLAR STAINLESS STEEL FACE PLATE. OVERRIDE KEY AVAILABLE ON REQUEST. COMPREHENSIVE RANGE OF CAMS AVAILABLE. CODE CHANGEABLE</p>		