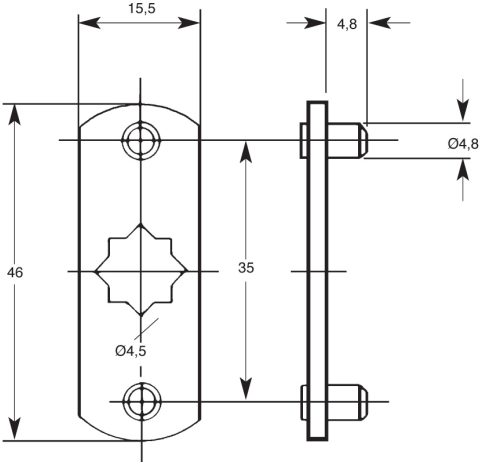
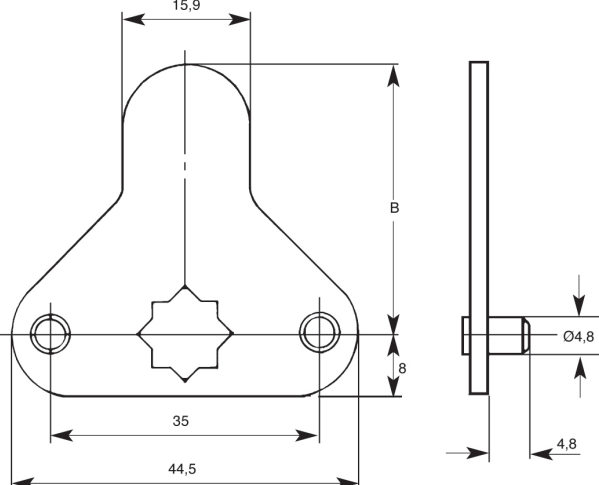
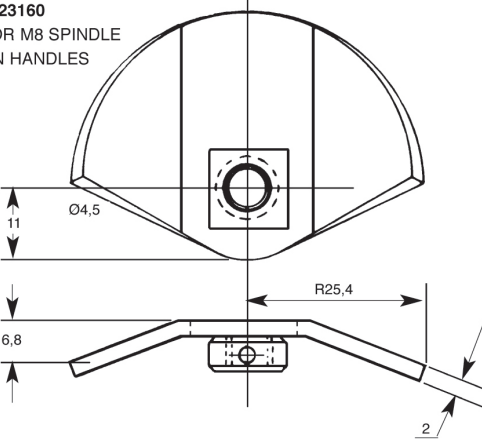
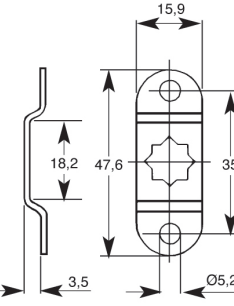
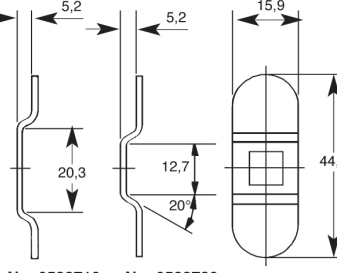

Technical-2 Point, 3 Point and Caulking Cams

2-POINT CAMS	3-POINT CAMS											
<p>DRIVE CAM</p>  <p>WITH STUMPS PART No. 6521820 WITHOUT STUMPS PART No. 6521821</p>	 <p>We have a range of special cams cranked towards, or away from, the handle. Details available on request. For large quantity orders a special cam can be produced to suit customers requirements</p> <table border="1" data-bbox="1117 1084 1364 1242"> <thead> <tr> <th>PART No.</th> <th>DIMENSION B</th> </tr> </thead> <tbody> <tr> <td>6522680</td> <td>36</td> </tr> <tr> <td>6523291</td> <td>44</td> </tr> <tr> <td>6522650</td> <td>60</td> </tr> <tr> <td>6522750</td> <td>63</td> </tr> </tbody> </table>		PART No.	DIMENSION B	6522680	36	6523291	44	6522650	60	6522750	63
PART No.	DIMENSION B											
6522680	36											
6523291	44											
6522650	60											
6522750	63											
CAULKING CAMS												
<p>PART No. 6523160 FOR M8 SPINDLE ON HANDLES</p>  <p>ALL CAMS SUPPLIED TO 'B' DIM TOLERANCE ± 1.0mm</p>												
	<p>RETAINING PLATE</p>  <p>No. 6521860 FOR USE WITH CAMLOCKS AND HANDLES</p>	<p>RETAINING PLATES</p>  <p>No. 6522710 No. 6522720 FOR USE ONLY WITH HANDLES</p>										